

Series 5000 B

Linear Power Shaker



VGS Configuration Optional

High "G" force, high volume

Introducing the 5000 B, FSI's latest advance in high "G" force, high volume linear motion shakers. FSI has designed this unit to achieve optimum performance. Even in the most challenging applications, the 5000 B achieves consistently high throughput. Processing rates vary with slurry content, percent solids and viscosity.

Exceptional reliability

Simplicity is the essence of every FSI design. Permanently sealed vibrators make lubrication systems totally unnecessary. Low 80-dB motor vibration eliminates the need for hearing protection. Each of the unit's four pre-tensioned screen panels can be installed or replaced independently of each other. Replacement takes less than three minutes and requires only a light to medium-weight hammer.

Lowest maintenance cost

FSI equipment has the lowest operational and maintenance costs in the industry. Routine maintenance is extremely minimal. Simple visual checks of screen panels, deck rubbers, inflation of air spring assemblies and quarterly torque checks of the vibrator motor bolts are all that is required. Fluid Systems, Inc. keeps you on-line for decades of trouble-free performance. It's that simple.

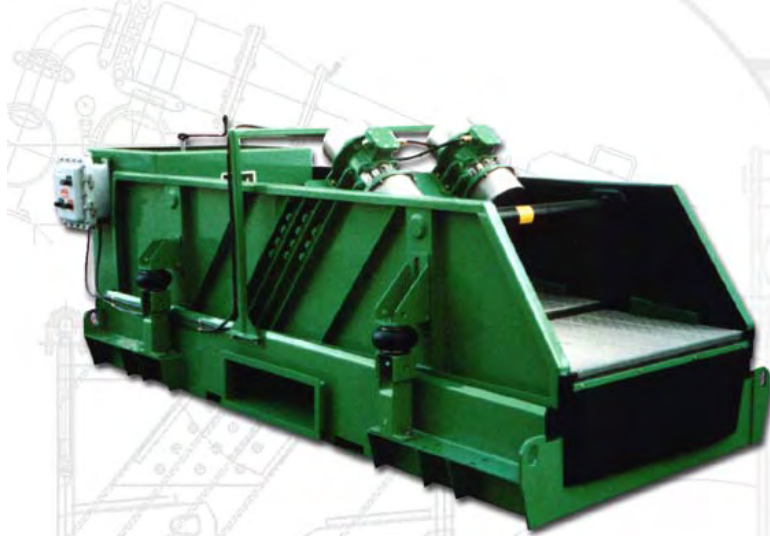

The FSI Difference

- **High "G" Force**
- **34 ft² [3.16 m²] screening area**
- **Simple design**
- **Rugged and reliable**
- **High performance**
- **Low maintenance**
- **Quick screen panel changes**
- **Small footprint**
- **No lubrication**
- **Low noise**



www.FluidSystems.com

Houston Office

16619 Aldine Westfield Rd
Houston, TX 77032
832-467-9898
FAX: 832-467-9897

New Orleans Office

2808 Engineers Road
Belle Chasse, LA 70037
504-393-1804
FAX: 504-393-5166

Series 5000 B

Linear Power Shaker



General Specifications

Series:	Series 5000
Model:	B
Motors:	Two each 1200, 1500 or 1800 rpm exp. proof or non-exp. proof available
Bearings:	Permanently sealed and lubricated
Motion:	Linear; 0.23" A (1200), 0.156" A (1500), 0.13" A (1800), 5.0 "G"
VGS:	Force adjustable to 7.0 "G" maximum
Deck adjustment:	Adjustable 0° to 5° adjustable
Screens:	Four each 29" x 42" pretensioned panels with <i>Wedgelok</i> fasteners
Screening area:	34 ft ² [3.16 m ²]
Overall dimensions:	146 7/8" L x 61" W x 54 5/8" H 3729mm x 1549mm x 1967mm

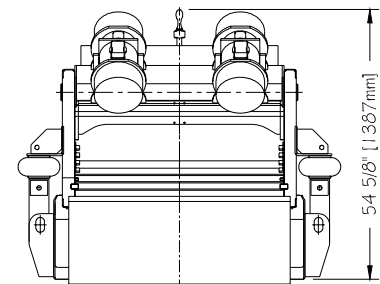
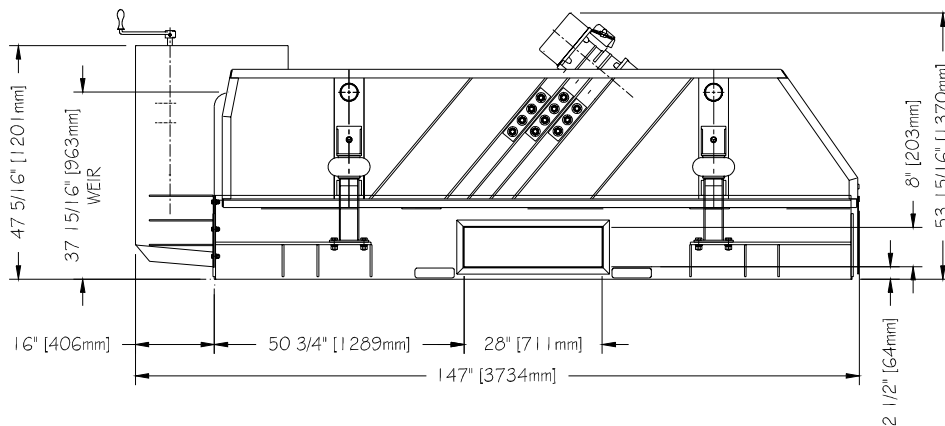
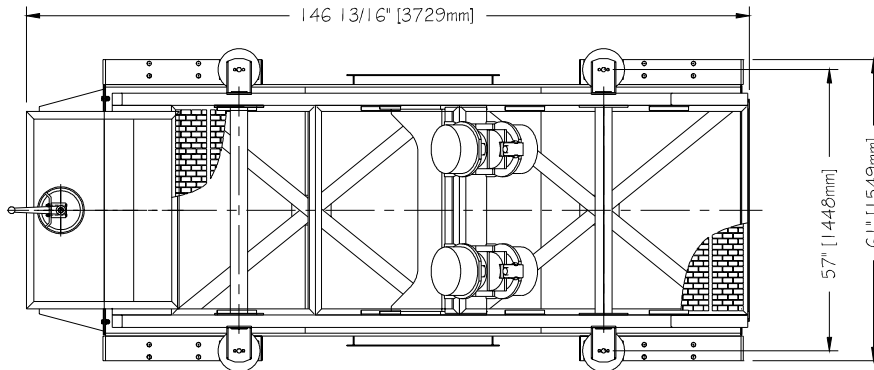

Fluid Systems, Inc.

Screen Sales, Manufacturing & Engineering

16619 AldineWestfield Rd • Houston, TX 77032 • TEL 832-467-9898 • FAX 832-467-9897

Sales & Service

2808 Engineers Road • Belle Chasse, LA 70037 • TEL 504-393-1804 • FAX 504-393-5166

Sales@FluidSystems.com